



brother

Quick Reference Guide

Kurzanleitung

Guide de référence rapide

Beknopte bedieningshandleiding

Guida di riferimento rapido

Guía de referencia rápida

Guia de referència rápida

Краткий справочник

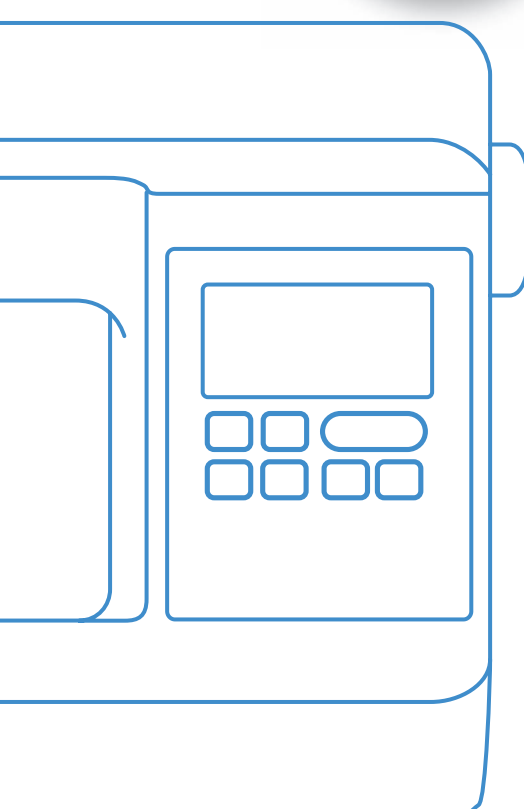

Be sure to read this document before using the machine.
We recommend that you keep this document nearby for future reference.

Lesen Sie dieses Dokument, bevor Sie die Maschine verwenden.
Es wird empfohlen, dieses Dokument griffbereit aufzubewahren, damit Sie jederzeit darin nachschlagen können.

Veillez à lire ce document avant d'utiliser la machine.
Nous vous conseillons de conserver ce document à portée de main pour vous y référer ultérieurement.

Lees dit document voordat u de machine gebruikt.
Houd dit document bij de hand, zodat u het kunt raadplegen.

Leggere questo documento prima di utilizzare la macchina.
Si consiglia di conservare questo documento a portata di mano per un eventuale riferimento futuro.

Lea este documento antes de utilizar la máquina.
Recomendamos que tenga este documento a mano por si necesita consultarlo más adelante.

Certifique-se de ler este documento antes de utilizar a máquina.
Recomendamos guardar este documento em um lugar de fácil acesso para futuras referências.

Обязательно прочитайте этот документ перед началом работы на машине!
Рекомендуется хранить данный документ в удобном месте, чтобы он был доступен для справок.

Before using your machine for the first time please read the “IMPORTANT SAFETY INSTRUCTIONS” in the Operation Manual.

Refer to the Operation Manual for detailed instructions.

In this guide, English screens are used for basic explanations.

For details on the built-in embroidery patterns, refer to the Embroidery Design Guide.

Bevor Sie die Maschine zum ersten Mal verwenden, lesen Sie bitte „WICHTIGE SICHERHEITSHINWEISE“ in der Bedienungsanleitung.

Ausführliche Hinweise finden Sie in der Bedienungsanleitung.

In dieser Anleitung werden für die grundlegenden Erläuterungen englischsprachige Bildschirme verwendet.

Weitere Informationen zu den internen Stickmustern finden Sie in dem Stickmuster-Katalog.

Avant d'utiliser votre machine pour la première fois, veuillez lire les « INSTRUCTIONS DE SÉCURITÉ IMPORTANTES » indiquées dans le manuel d'instructions.

Reportez-vous au manuel d'instructions pour des informations détaillées.

Les écrans de ce guide sont en Anglais pour les explications de base.

Pour plus de détails sur les motifs de broderie intégrés, consultez le guide de motifs de broderie.

Lees – voordat u de machine de eerste keer gebruikt – de “BELANGRIJKE VEILIGHEIDSINSTRUCTIES” in de Bedieningshandleiding.

In de bedieningshandleiding vindt u uitvoerige aanwijzingen.

In deze gids worden Engelse schermen gebruikt bij de uitleg van basisbewerkingen.

Meer bijzonderheden over de ingebouwde borduurpatronen vindt u in de Borduurontwerpen bedieningshandleiding.

Prima di utilizzare la macchina per la prima volta, leggere “IMPORTANTI ISTRUZIONI DI SICUREZZA” nel manuale d'istruzione.

Per le istruzioni dettagliate, consultare il manuale di istruzioni.

Nella presente guida si utilizzano le schermate in inglese per le spiegazioni di base.

Per i dettagli sui motivi da ricamo incorporati, consultare la Guida ai ricami.

Antes de utilizar la máquina por primera vez, lea las “INSTRUCCIONES DE SEGURIDAD IMPORTANTES” en el Manual de instrucciones.

Consulte las instrucciones detalladas en el manual de instrucciones.

En esta guía, para las explicaciones básicas se utilizan pantallas en inglés.

Para más detalles acerca de los patrones de bordado embutidos, consulte la Guía de diseños de bordado.

Antes de utilizar a sua máquina pela primeira vez, leia as “INSTRUÇÕES DE SEGURANÇA IMPORTANTES” no Manual de Operações.

Consulte o manual de operações para obter instruções detalhadas.

Neste manual, as telas em inglês são usadas para as explicações básicas.

Para obter detalhes sobre os padrões de bordado incluídos, consulte o Guia de desenhos de bordado.

Перед первым использованием машины прочитайте раздел “ВАЖНЫЕ ИНСТРУКЦИИ ПО БЕЗОПАСНОСТИ” в Руководстве пользователя.

Подробные инструкции см. в руководстве пользователя.

В данном руководстве в качестве иллюстраций используются англоязычные экраны.

Подробная информация о встроенных рисунках для вышивания приведена в Руководстве по дизайнам для вышивания.

Contents

Winding/Installing the Bobbin.....	3
Upper Threading	5
Selecting and Sewing Stitches.....	7
◆ Utility Stitches	7
◆ Decorative Stitches.....	8
◆ Character stitches	8
Summary of Stitch Patterns.....	9
◆ Utility Stitches	9
◆ Decorative Stitches.....	10
◆ Character stitches	11

Inhalt

Aufspulen/Einsetzen der Spule.....	3
Einfädeln des Oberfadens	5
Auswählen und Nähen von Stichen	7
◆ Nutzstiche	7
◆ Dekorstiche	8
◆ Buchstabenstiche.....	8
Stich-Übersicht.....	9
◆ Nutzstiche	9
◆ Dekorstiche	10
◆ Buchstabenstiche.....	11

Table des matières

Bobinage/installation de la canette.....	3
Enfilage supérieur	5
Sélection et couture de points	7
◆ Points utilitaires	7
◆ Points décoratifs	8
◆ Points de caractères.....	8
Sommaire des motifs de point.....	9
◆ Points utilitaires	9
◆ Points décoratifs	10
◆ Points de caractères.....	11

Inhoudsopgave

Spoel opwinden/installeren	3
Inrijgen van de bovendraad	5
Steken selecteren en naaien.....	7
◆ Naaisteken	7
◆ Decoratieve steken	8
◆ Lettersteken	8
Steken overzicht	9
◆ Naaisteken	9
◆ Decoratieve steken	10
◆ Lettersteken	11

Sommario

Avvolgimento/Installazione della spolina	3
Infilatura superiore	5
Selezione e cucitura dei vari tipi di punto	7
◆ Punti utili.....	7
◆ Punti decorativi	8
◆ Punti a caratteri	8
Sommario dei punti	9
◆ Punti utili.....	9
◆ Punti decorativi	10
◆ Punti a caratteri	11

Contenido

Devanar/colocar la bobina	3
Hilo superior	5
Seleccionar y coser puntadas.....	7
◆ Puntadas de utilidad	7
◆ Puntadas decorativas	8
◆ Puntadas de carácter	8
Resumen de tipos de puntada	9
◆ Puntadas de utilidad	9
◆ Puntadas decorativas	10
◆ Puntadas de carácter	11

Índice

Encher/Instalar a bobina.....	3
Passagem da linha superior.....	5
Selecionar e costurar pontos	7
◆ Pontos úteis	7
◆ Pontos decorativos	8
◆ Pontos de caracteres.....	8
Resumo dos padrões de ponto	9
◆ Pontos úteis	9
◆ Pontos decorativos	10
◆ Pontos de caracteres.....	11

Содержание

Намотка/установка шпульки	3
Заправка верхней нити.....	5
Выбор и выполнение строчек	7
◆ Основные строчки.....	7
◆ Декоративные строчки.....	8
◆ Символьные строчки	8
Схемы строчек	9
◆ Основные строчки.....	9
◆ Декоративные строчки.....	10
◆ Символьные строчки	11



Winding/Installing the Bobbin

Aufspulen/Einsetzen der Spule

Bobinage/installation de la canette

Spool opwinden/installeren

Avvolgimento/Installazione della spolina

Devanar/colocar la bobina

Encher/Instalar a bobina

Намотка/установка шпульки

Follow the steps below in numerical order. Refer to the Operation Manual for detailed instructions.
 Führen Sie die folgenden Schritte in der numerischen Reihenfolge aus. Ausführliche Hinweise finden Sie in der Bedienungsanleitung.
 Respectez les étapes ci-dessous, dans l'ordre numérique. Reportez-vous au manuel d'instructions pour des informations détaillées.
 Volg onderstaande stappen in numerieke volgorde. In de bedieningshandleiding vindt u uitvoerige aanwijzingen.
 Seguire i passaggi di seguito, in ordine numerico. Per le istruzioni dettagliate, consultare il manuale di istruzioni.
 Siga los pasos descritos a continuación, en orden numérico. Consulte las instrucciones detalladas en el manual de instrucciones.
 Siga as etapas abaixo, em ordem numérica. Consulte o manual de operações para obter instruções detalhadas.
 Выполните описанные ниже действия по порядку номеров. Подробные инструкции см. в руководстве пользователя.

Use the plastic bobbin that comes with this machine or bobbins of the same type.
 Verwenden Sie die Kunststoffspule, die mit dieser Maschine geliefert wird, oder Spulen vom gleichen Typ.
 Utilisez la canette en plastique fournie avec cette machine ou des canettes du même type.
 Gebruik de plastic spool die is meegeleverd met deze machine of spoulen van hetzelfde type.
 Utilizzare la spolina di plastica in dotazione con la macchina o spoline dello stesso tipo.
 Utilice la bobina de plástico suministrada con esta máquina o bobinas del mismo tipo.
 Use a bobina plástica que acompanha a máquina ou bobinas do mesmo tipo.
 Используйте прилагаемую к машине пластиковую шпульку или шпульки такого же типа.

11,5 mm (approx. 7/16 inch)
 11,5 mm (ca. 7/16 Zoll)
 11,5 mm (env. 7/16" / pouce)
 11,5 mm (ca. 7/16 inch)
 11,5 mm (circa 7/16 inch)
 11,5 mm (aprox. 7/16 pulg.)
 11,5 mm (aprox. 7/16 polegada)
 11,5 mm (прим. 7/16 дюйма)

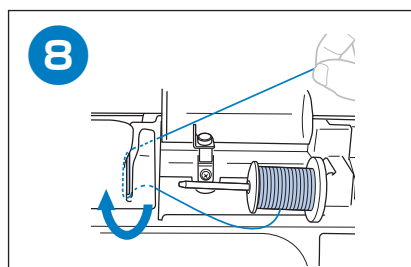
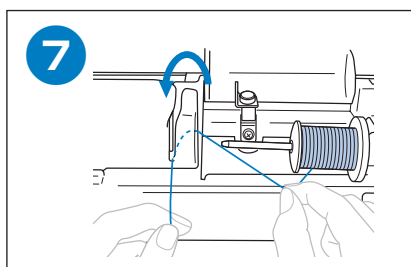
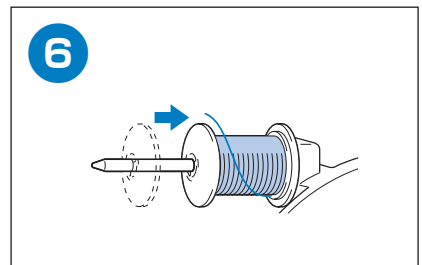
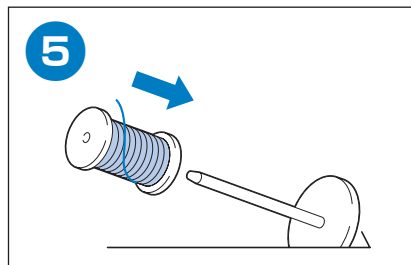
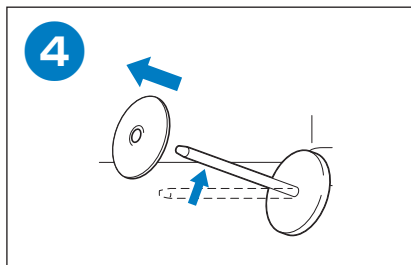
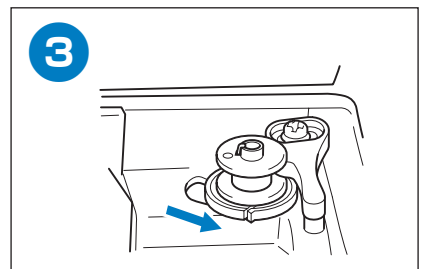
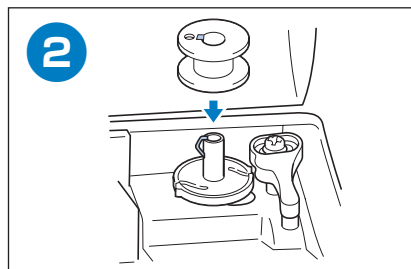
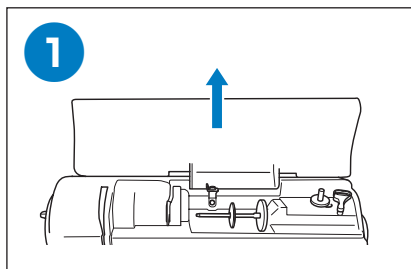
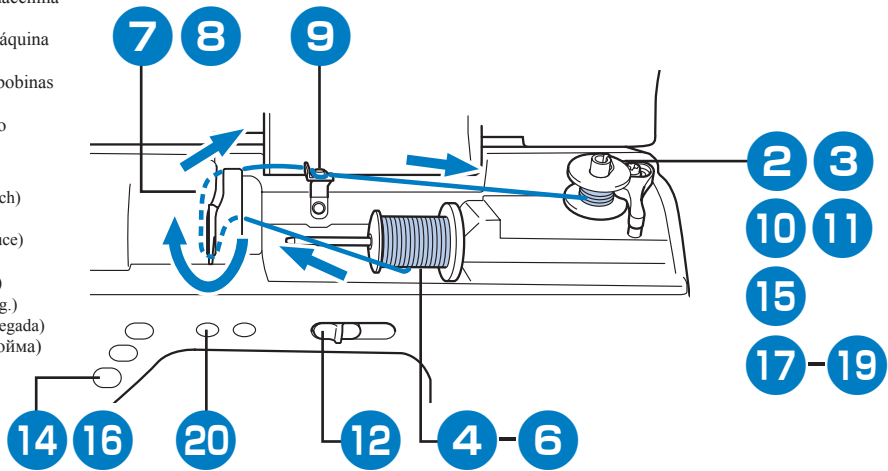

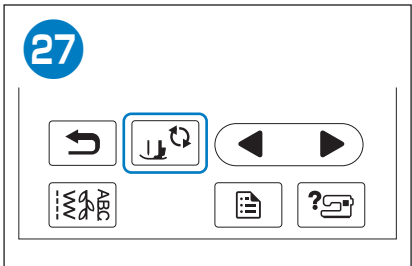
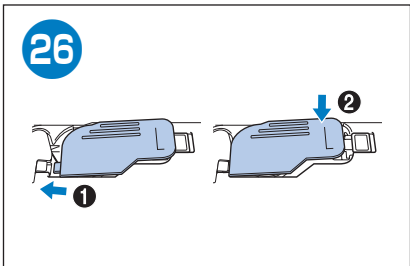
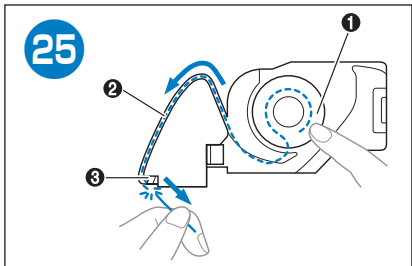
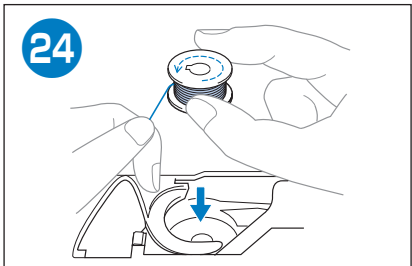
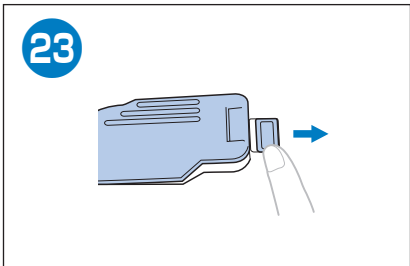
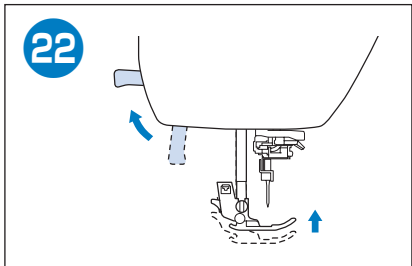
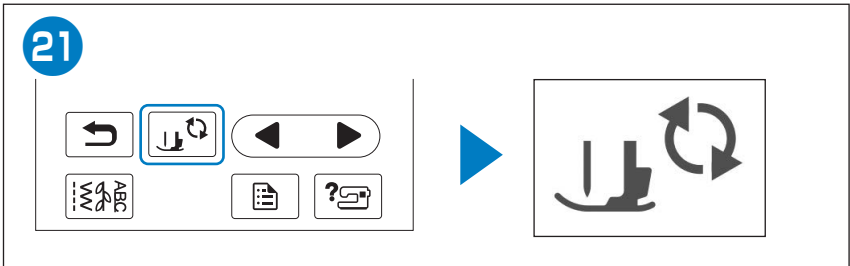
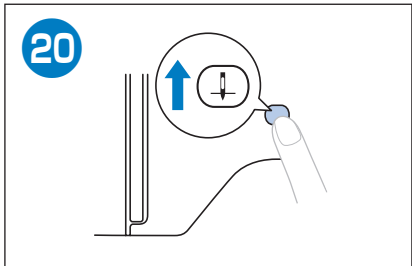
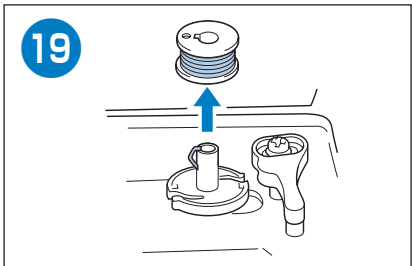
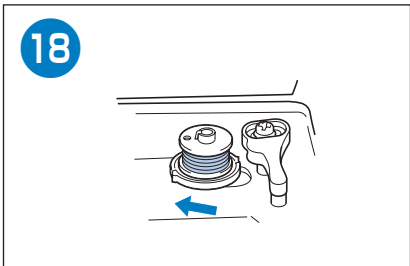
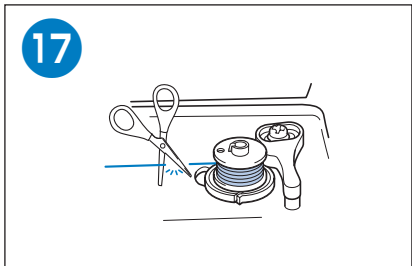
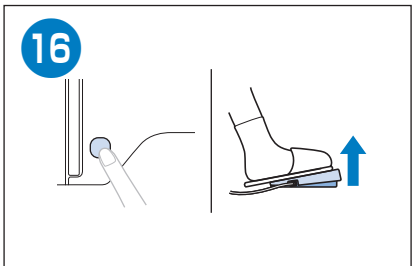
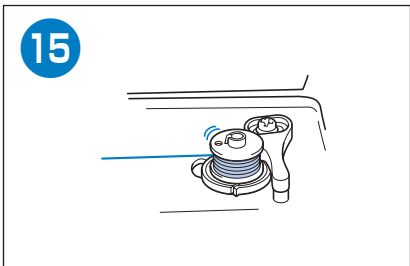
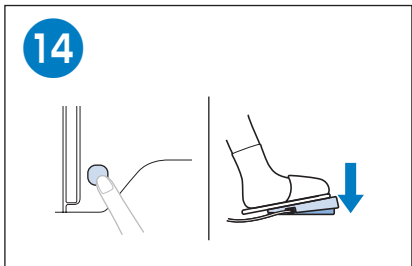
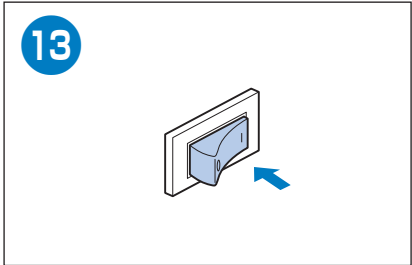
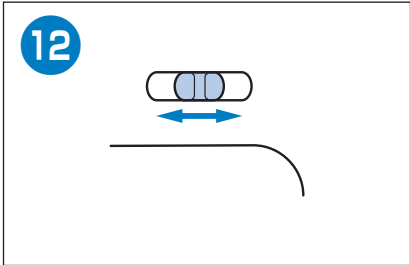
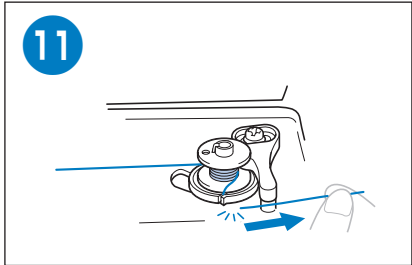
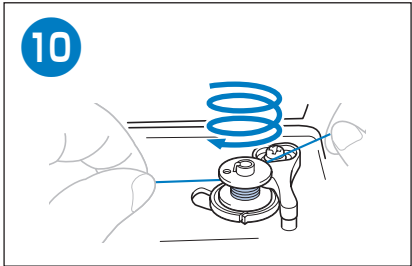
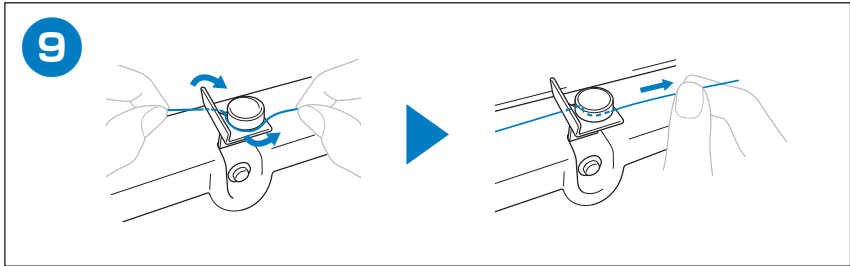



Upper Threading
Einfädeln des Oberfadens
Enfilage supérieur
Inrijgen van de bovendraad
Infilatura superiore
Hilo superior
Passagem da linha superior
Заправка верхней нити

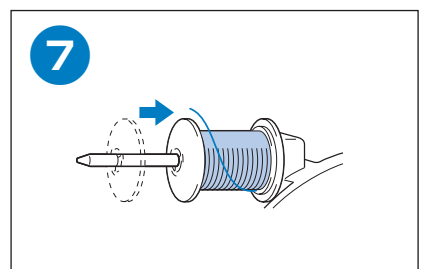
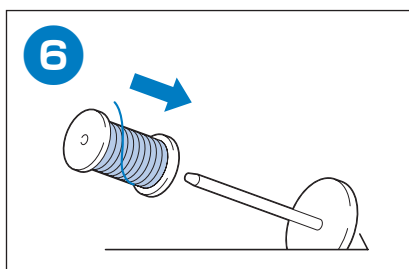
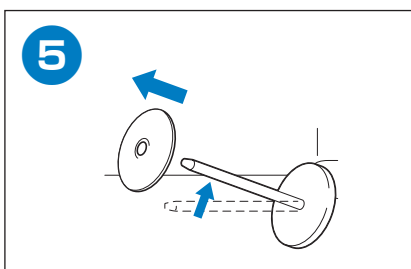
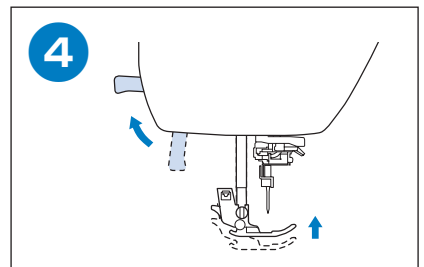
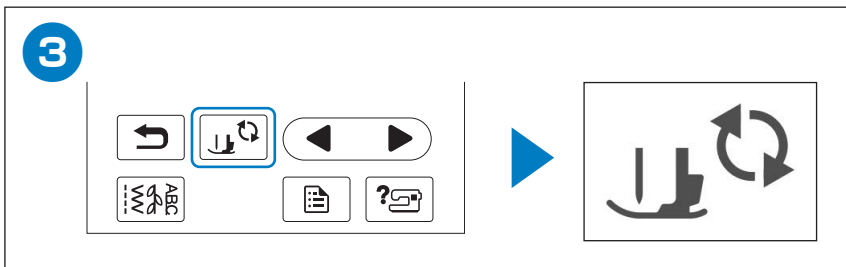
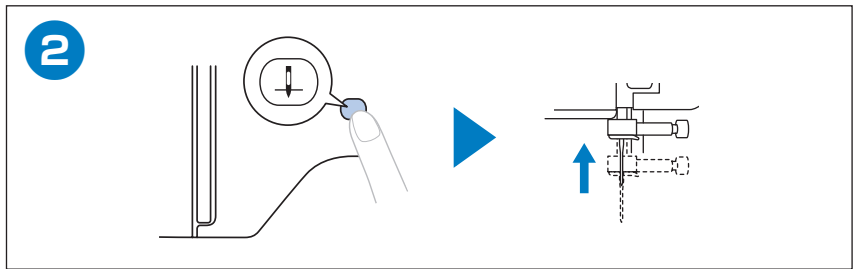
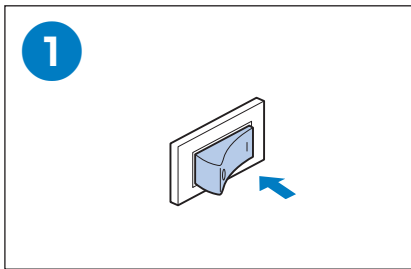
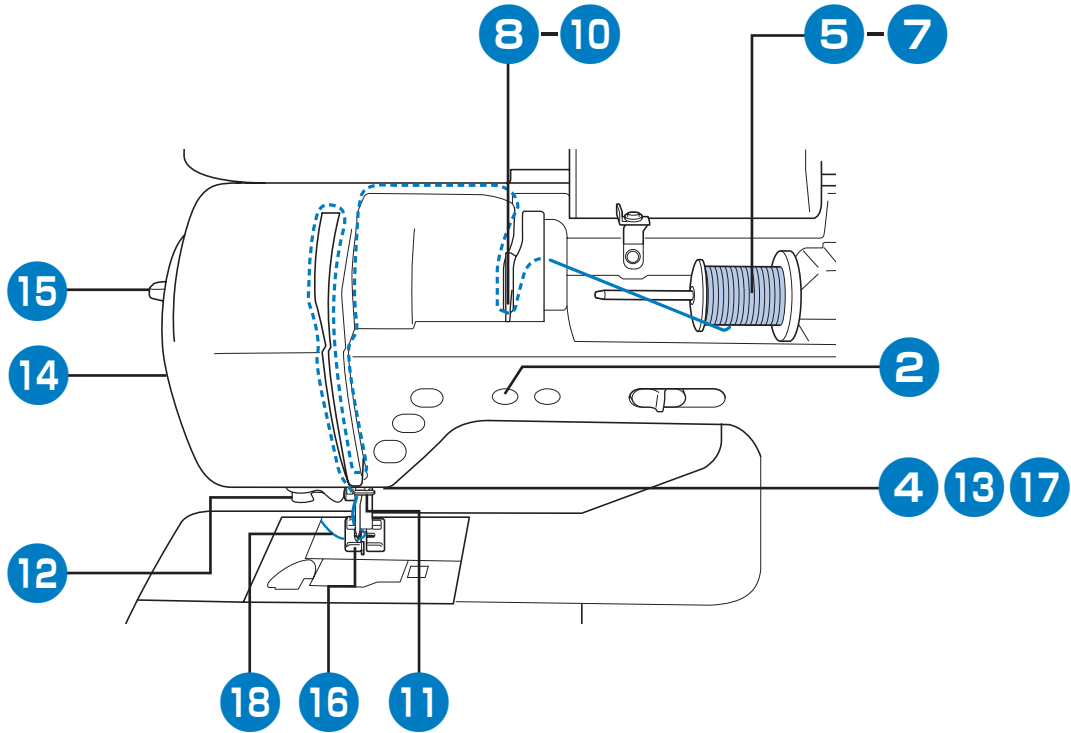

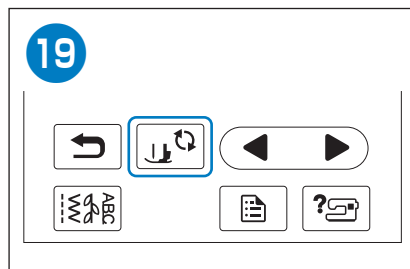
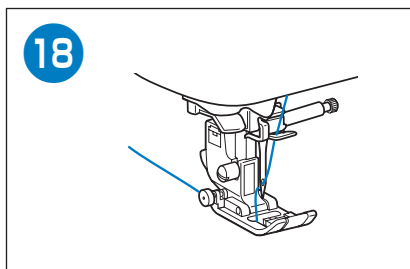
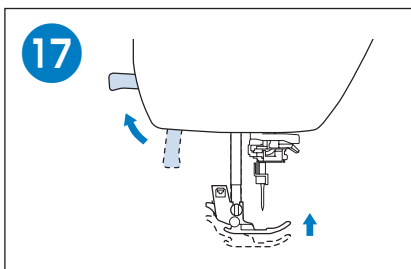
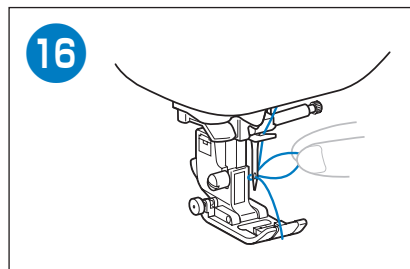
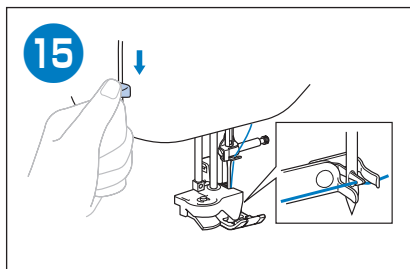
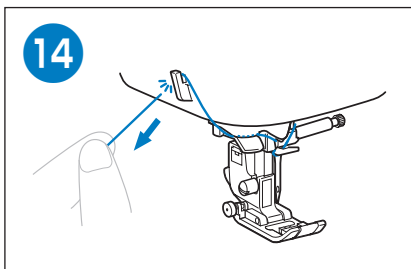
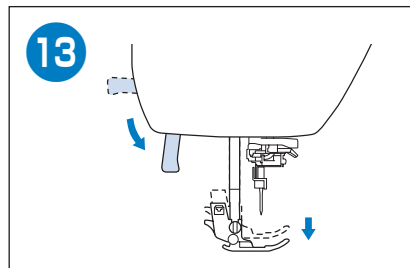
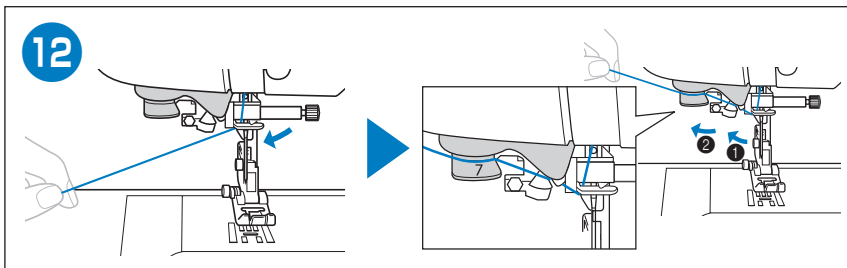
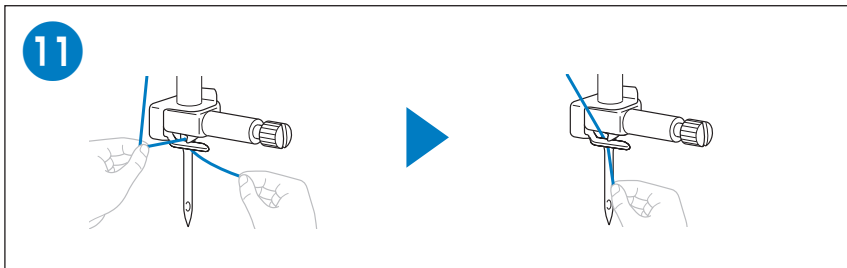
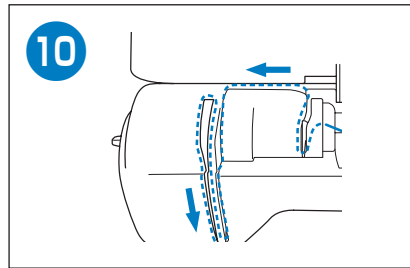
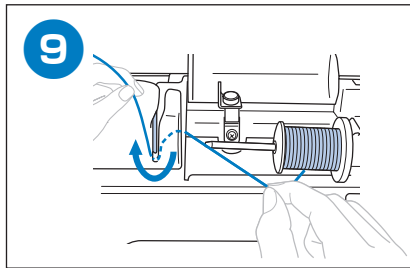
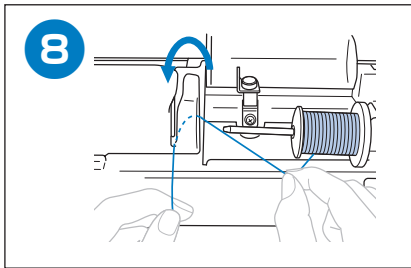

Selecting and Sewing Stitches

Auswählen und Nähen von Stichen

Sélection et couture de points

Steken selecteren en naaien

Selezione e cucitura dei vari tipi di punto

Seleccionar y coser puntadas

Выбор и выполнение строчек

◆ Utility Stitches
◆ Punti utili

◆ Nutzstiche
◆ Puntadas de utilidad

◆ Points utilitaires
◆ Pontos úteis

◆ Naaisteken
◆ Основные строчки

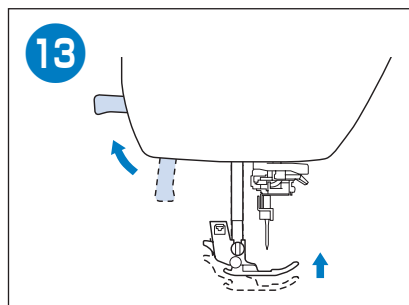
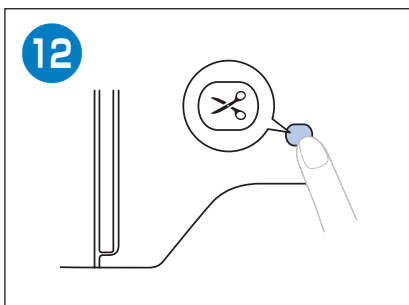
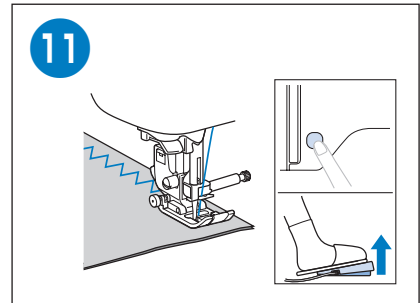
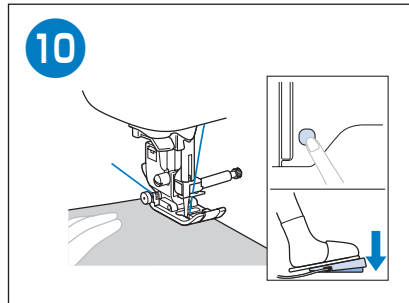
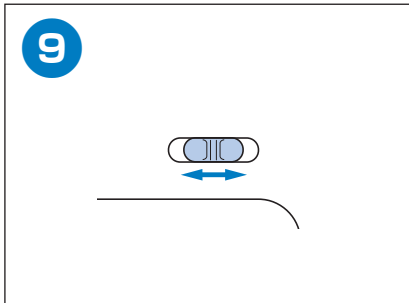
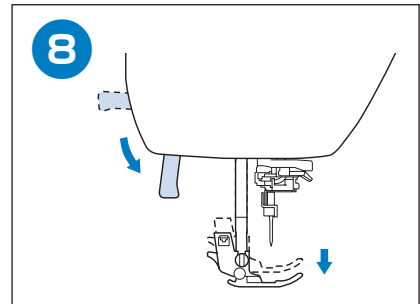
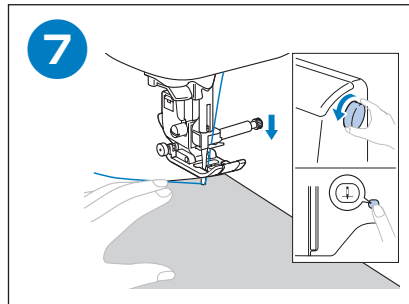
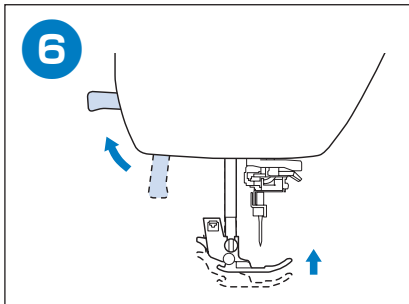
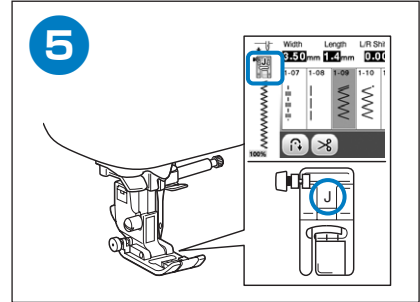
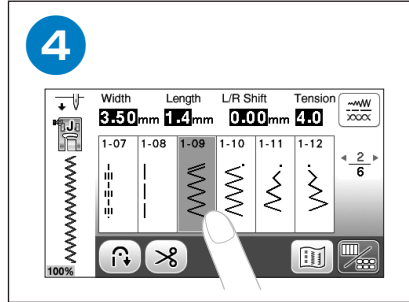
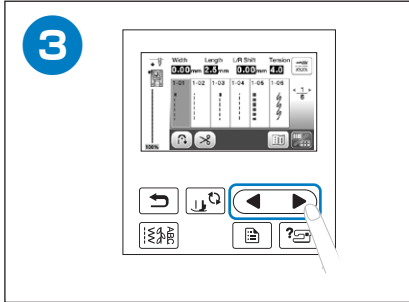
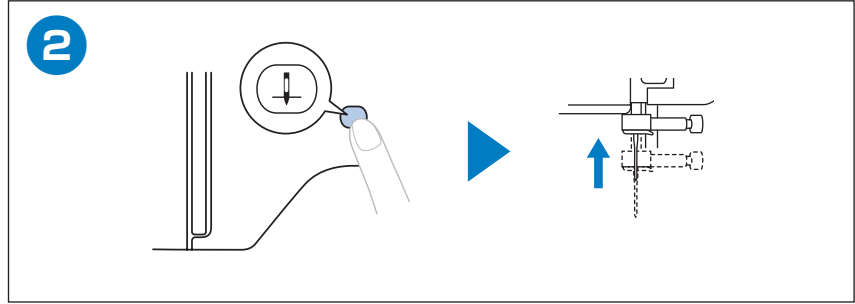
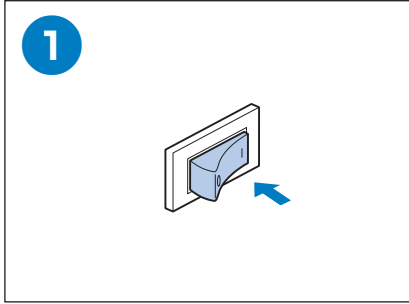

◆ Decorative Stitches ◆ Dekorstiche ◆ Points décoratifs ◆ Decoratieve steken
 ◆ Punt decorativi ◆ Puntadas decorativas ◆ Pontos decorativos ◆ Декоративные строчки

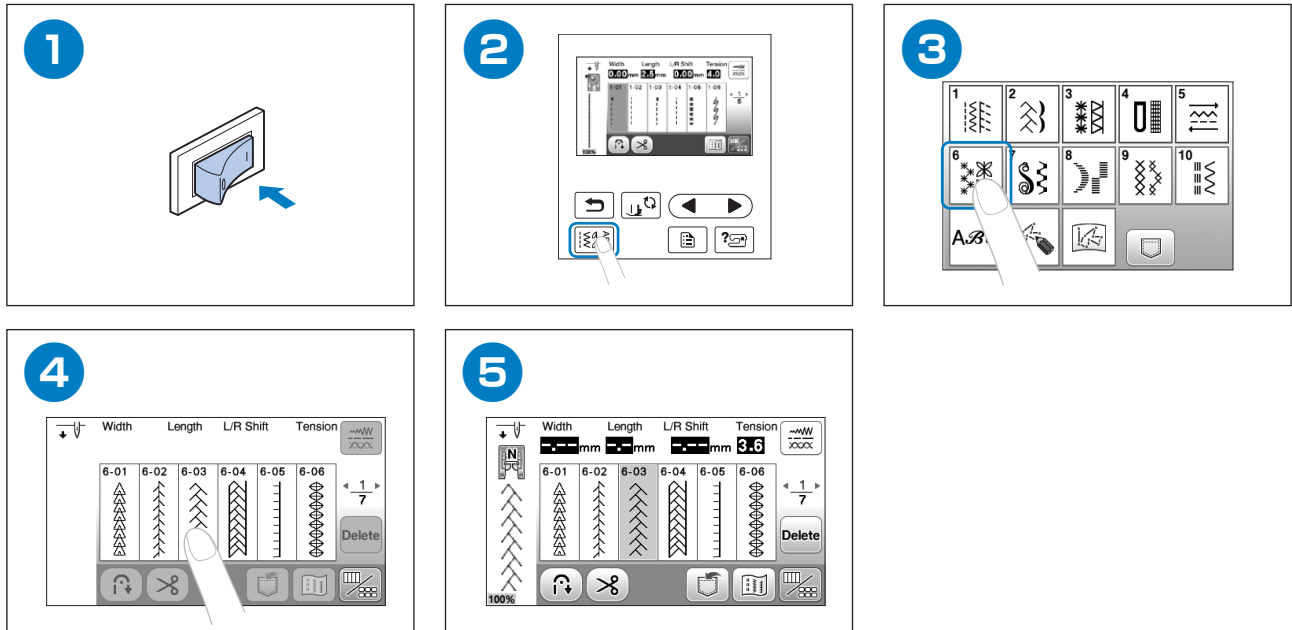

◆ Character stitches ◆ Buchstabenstiche ◆ Points de caractères ◆ Lettersteken
 ◆ Punt a caratteri ◆ Puntadas de carácter ◆ Pontos de caracteres ◆ Символьные строчки

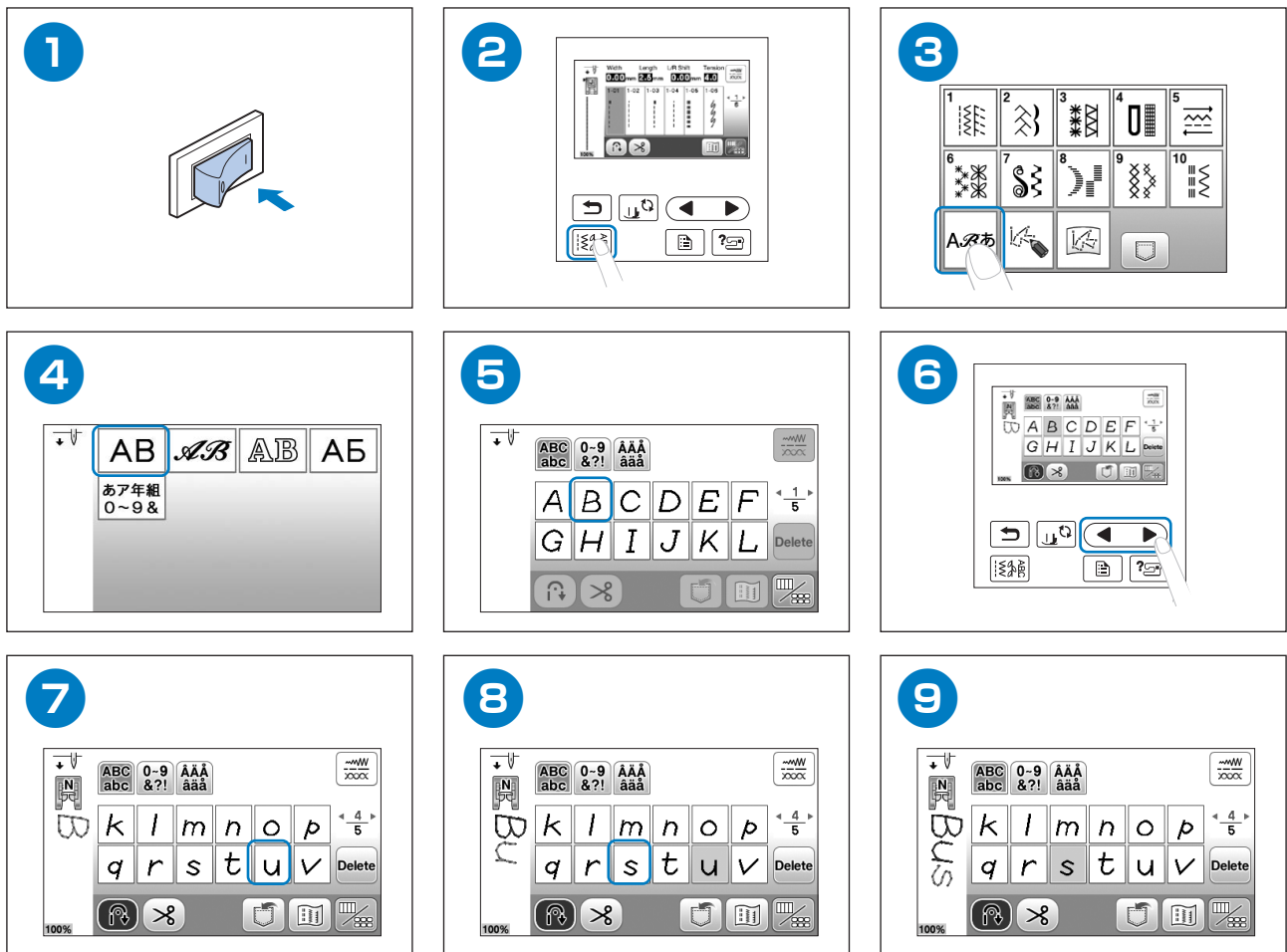



Summary of Stitch Patterns
Stich-Übersicht
Sommaire des motifs de point
Steken overzicht
Sommario dei punti
Resumen de tipos de puntada
Resumo dos padrões de ponto
Схемы строчек

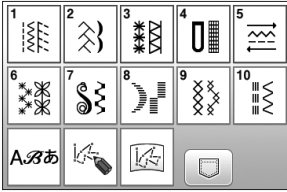

◆ Utility Stitches
 ◆ Punti utili

◆ Nutztstiche
 ◆ Puntadas de utilidad

◆ Points utilitaires
 ◆ Pontos úteis

◆ Naaisteken
 ◆ Основные строчки

• 1-01~1-35

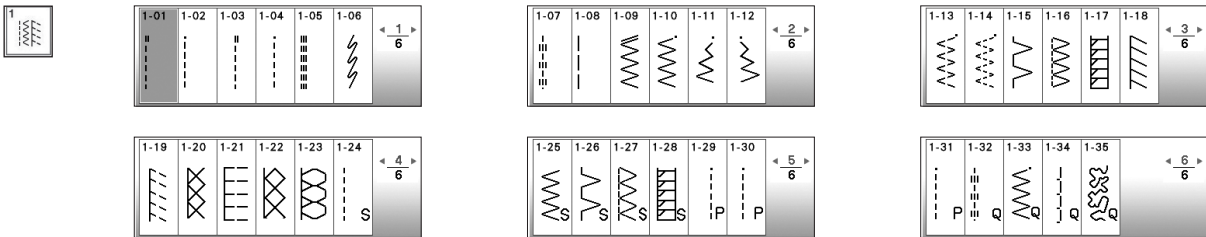

• 2-01~2-20

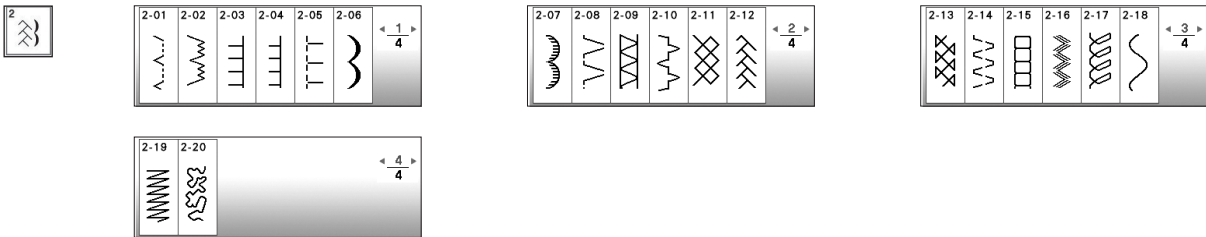

• 3-01~3-22

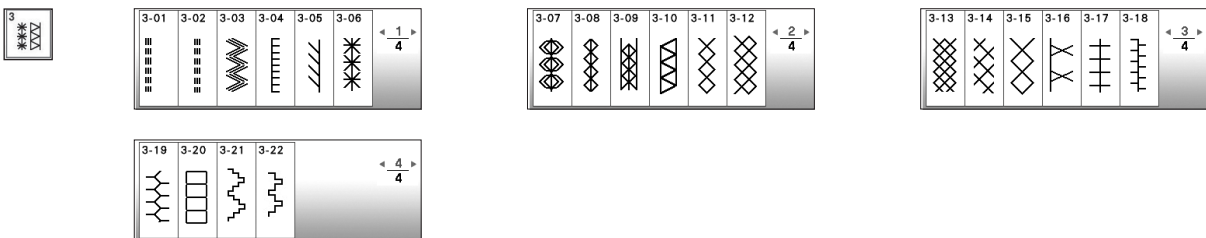

• 4-01~4-15

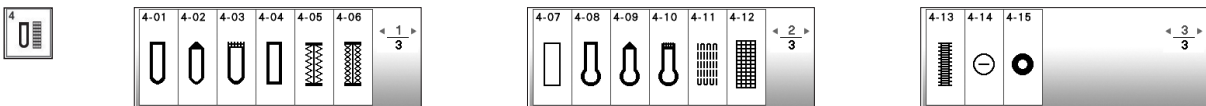

• 5-01~5-08

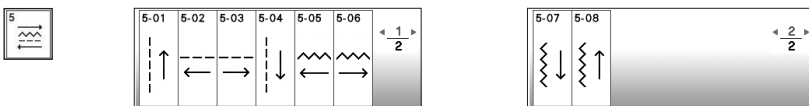

◆ Decorative Stitches
◆ Puntis decorativi

◆ Dekorstiche
◆ Puntadas decorativas

◆ Points décoratifs
◆ Pontos decorativos

◆ Decoratieve steken
◆ Декоративные строчки

• 6-01~6-40

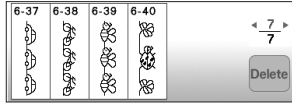
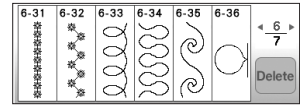
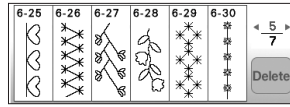
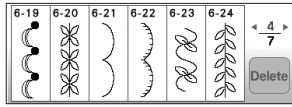
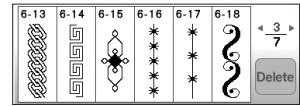
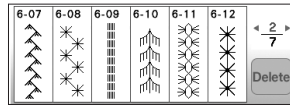
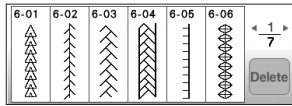

• 7-01~7-12

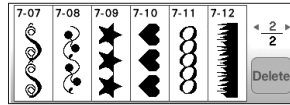
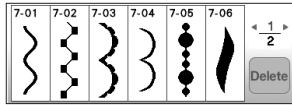

• 8-01~8-17

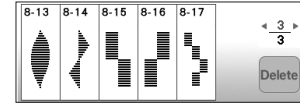
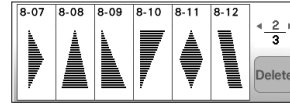
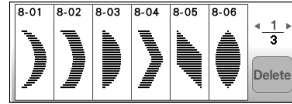

• 9-01~9-14

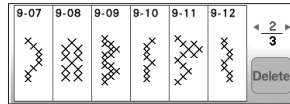
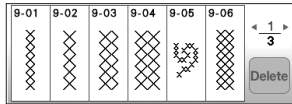

• 10-01~10-58

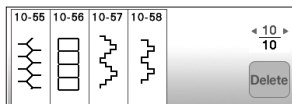
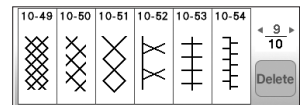
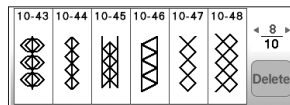
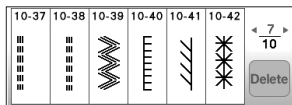
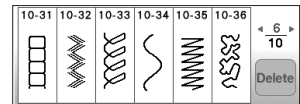
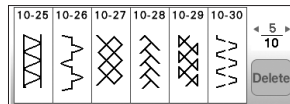
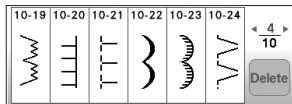
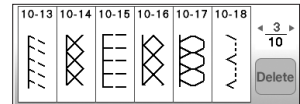
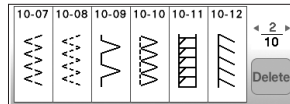
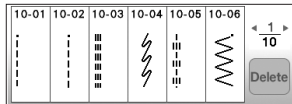

◆ Character stitches
◆ Punti a caratteri

◆ Buchstabenstiche
◆ Puntadas de carácter

◆ Points de caractères
◆ Pontos de caracteres

◆ Lettersteken
◆ Символьные строчки

A.33a ▶ AB

ABC abc	0-9 &?! AAA aaa	→NW ↖↘				
A	B	C	D	E	F	← 1/5
G	H	I	J	K	L	Delete

ABC abc	0-9 &?! AAA aaa	→NW ↖↘				
M	N	O	P	Q	R	← 2/5
S	T	U	V	W	X	Delete

ABC abc	0-9 &?! AAA aaa	→NW ↖↘				
Y	Z	α	b	c	d	← 3/5
e	f	g	h	i	j	Delete

ABC abc	0-9 &?! AAA aaa	→NW ↖↘				
k	l	m	n	o	p	← 4/5
q	r	s	t	u	v	Delete

ABC abc	0-9 &?! AAA aaa	→NW ↖↘			
w	x	y	z	—	← 5/5
Delete					

ABC abc	0-9 &?! AAA aaa	→NW ↖↘				
0	1	2	3	4	5	← 1/5
6	7	8	9	#	%	Delete

ABC abc	0-9 &?! AAA aaa	→NW ↖↘				
\$	£	€	¥	—	+	← 2/5
×	÷	=	*	.	,	Delete

ABC abc	0-9 &?! AAA aaa	→NW ↖↘				
&	?	!	@	<	>	← 3/5
()	[]	/	\	Delete

ABC abc	0-9 &?! AAA aaa	→NW ↖↘				
~	:	;	©	®	™	← 4/5
“	”	”	’	‘	’	Delete

ABC abc	0-9 &?! AAA aaa	→NW ↖↘
—	← 5/5	
Delete		

ABC abc	0-9 &?! AAA aaa	→NW ↖↘				
Â	Ä	Å	Æ	ǎ	á	← 1/5
â	ä	å	æ	ç	Delete	

ABC abc	0-9 &?! AAA aaa	→NW ↖↘				
ç	Ð	È	É	Ê	Ë	← 2/5
è	é	ê	ë	Í	Ï	Delete

ABC abc	0-9 &?! AAA aaa	→NW ↖↘				
Ï	ì	í	î	ï	Ñ	← 3/5
ñ	ô	ö	ø	õ	Delete	

ABC abc	0-9 &?! AAA aaa	→NW ↖↘				
œ	ò	ó	ô	ö	ø	← 4/5
õ	æ	ř	t	Û	Ü	Delete

ABC abc	0-9 &?! AAA aaa	→NW ↖↘				
ù	ú	û	ü	z	ƒ	← 5/5
ƒ	ß	—	Delete			

A.33b ▶ AB

ABC abc	0-9 &?! AAA aaa	→NW ↖↘				
A	B	C	D	E	F	← 1/5
G	H	I	J	K	L	Delete

ABC abc	0-9 &?! AAA aaa	→NW ↖↘				
M	N	O	P	Q	R	← 2/5
S	T	U	V	W	X	Delete

ABC abc	0-9 &?! AAA aaa	→NW ↖↘				
Y	Z	α	b	c	d	← 3/5
e	f	g	h	i	j	Delete

ABC abc	0-9 &?! AAA aaa	→NW ↖↘				
k	l	m	n	o	p	← 4/5
q	r	s	t	u	v	Delete

ABC abc	0-9 &?! AAA aaa	→NW ↖↘			
w	x	y	z	—	← 5/5
Delete					

ABC abc	0-9 &?! AAA aaa	→NW ↖↘				
0	1	2	3	4	5	← 1/5
6	7	8	9	#	%	Delete

ABC abc	0-9 &?! AAA aaa	→NW ↖↘				
\$	£	€	¥	—	+	← 2/5
×	÷	=	*	.	,	Delete

ABC abc	0-9 &?! AAA aaa	→NW ↖↘				
&	?	!	@	<	>	← 3/5
()	[]	/	\	Delete

ABC abc	0-9 &?! AAA aaa	→NW ↖↘				
~	:	;	©	®	™	← 4/5
“	”	”	’	‘	’	Delete

ABC abc	0-9 &?! AAA aaa	→NW ↖↘
—	← 5/5	
Delete		

ABC abc	0-9 &?! AAA aaa	→NW ↖↘				
À	Ä	Å	Æ	ǎ	á	← 1/5
à	ä	å	æ	ç	Delete	

ABC abc	0-9 &?! AAA aaa	→NW ↖↘				
ç	Ð	È	É	Ê	Ë	← 2/5
è	é	ê	ë	Í	Ï	Delete

ABC abc	0-9 &?! AAA aaa	→NW ↖↘				
Ï	ì	í	î	ï	Ñ	← 3/5
ñ	ô	ö	ø	õ	Delete	

ABC abc	0-9 &?! AAA aaa	→NW ↖↘				
œ	ò	ó	ô	ö	ø	← 4/5
õ	æ	ř	t	Û	Ü	Delete

ABC abc	0-9 &?! AAA aaa	→NW ↖↘				
ù	ú	û	ü	z	ƒ	← 5/5
ƒ	ß	—	Delete			

А.Ә.ә ▶ АБ

ABC 0-9 AAA
abc &?! áää

A	B	C	D	E	F
G	H	I	J	K	L

← 1/5 Delete

ABC 0-9 AAA
abc &?! áää

M	N	O	P	Q	R
S	T	U	V	W	X

← 2/5 Delete

ABC 0-9 AAA
abc &?! áää

Y	Z	a	b	c	d
e	f	g	h	i	j

← 3/5 Delete

ABC 0-9 AAA
abc &?! áää

k	l	m	n	o	p
q	r	s	t	u	v

← 4/5 Delete

ABC 0-9 AAA
abc &?! áää

w	x	y	z	_	
---	---	---	---	---	--

← 5/5 Delete

ABC 0-9 AAA
abc &?! áää

0	1	2	3	4	5
6	7	8	9	#	%

← 1/5 Delete

ABC 0-9 AAA
abc &?! áää

§	€	¢	¥	¤	+
×	÷	≡	✖	°	,

← 2/5 Delete

ABC 0-9 AAA
abc &?! áää

&	?	!	⊙	<	>
()	[]	/	\

← 3/5 Delete

ABC 0-9 AAA
abc &?! áää

~	°	º	⊙	⊚	™
σ	ρ	π	ν	δ	ρ

← 4/5 Delete

ABC 0-9 AAA
abc &?! áää

_					
---	--	--	--	--	--

← 5/5 Delete

ABC 0-9 AAA
abc &?! áää

À	Ä	Å	Æ	à	á
â	ã	ä	å	æ	ç

← 1/5 Delete

ABC 0-9 AAA
abc &?! áää

Ċ	Đ	Ď	É	Ê	Ë
È	É	Ê	Ë	Í	Ĭ

← 2/5 Delete

ABC 0-9 AAA
abc &?! áää

İ	ı	í	ï	ı	Ń
Ň	ň	Ō	ō	Ø	Ŏ

← 3/5 Delete

ABC 0-9 AAA
abc &?! áää

œ	ò	ó	ô	ö	ø
õ	œ	ƒ	ţ	Ů	ů

← 4/5 Delete

ABC 0-9 AAA
abc &?! áää

Ù	ú	Û	ü	ž	Ɔ
Ɔ	Ɔ	_			

← 5/5 Delete

А.Ә.ә ▶ АБ

АБВ абв 0-9
&?! &?!

А	Б	В	Г	Д	Е
Ё	Ж	З	И	Й	К

← 1/4 Delete

АБВ абв 0-9
&?! &?!

Л	М	Н	О	П	Р
С	Т	У	Ф	Х	Ц

← 2/4 Delete

АБВ абв 0-9
&?! &?!

Ч	Ш	Щ	Ь	Ы	Ъ
Э	Ю	Я	Г	Е	І

← 3/4 Delete

АБВ абв 0-9
&?! &?!

İ	ÿ	ħ	ĥ	Ј	Љ
Њ	Ц	Ѓ	Ѕ	Ќ	_

← 4/4 Delete

АБВ абв 0-9
&?! &?!

а	б	в	г	д	е
ё	ж	з	и	й	к

← 1/4 Delete

АБВ абв 0-9
&?! &?!

л	м	н	о	п	р
с	т	у	ф	х	ц

← 2/4 Delete

АБВ абв 0-9
&?! &?!

ч	ш	щ	ь	ы	ъ
э	ю	я	г	е	і

← 3/4 Delete

АБВ абв 0-9
&?! &?!

ı	ÿ	ħ	ĥ	Ј	Љ
Њ	Ц	Ѓ	Ѕ	Ќ	_

← 4/4 Delete

АБВ абв 0-9
&?! &?!

0	1	2	3	4	5
6	7	8	9	-	.

← 1/2 Delete

АБВ абв 0-9
&?! &?!

,	&	?	!	()
/	'	_			

← 2/2 Delete

Katakana characters: One of the Japanese character sets.
 Katakana-Zeichen: Einer der japanischen Zeichensätze.
 Caractères Katakana : Un des ensembles de caractères japonais.
 Catalaan-tekens: Een van de Japanse tekensets.
 Caratteri Katakana: Uno dei set di caratteri giapponesi.
 Caracteres Katakana: Uno de los diferentes conjuntos de caracteres japoneses.
 Caracteres Katakana: Um dos conjuntos de caracteres japoneses.
 Катакана: Один из японских алфавитов.

Hiragana characters: One of the Japanese character sets.
 Hiragana-Zeichen: Einer der japanischen Zeichensätze.
 Caractères Hiragana : Un des ensembles de caractères japonais.
 Hiragana-tekens: Een van de Japanse tekensets.
 Caratteri Hiragana: Uno dei set di caratteri giapponesi.
 Caracteres Hiragana: Uno de los diferentes conjuntos de caracteres japoneses.
 Caracteres Hiragana: Um dos conjuntos de caracteres japoneses.
 Хирагана: Один из японских алфавитов.

Arabic numerals, Japanese Kanji numerals
 Arabische Ziffern, japanische Kanji-Ziffern
 Chiffres arabes, chiffres Kanji japonais
 Arabische cijfers, Japanse Kanji-cijfers
 Numeri arabi, numeri Kanji giapponesi
 Números arábigos, números Kanji japoneses
 Numerais arábicos, numerais japoneses em Kanji
 Арабские цифры и японские иероглифы-цифры

Kanji characters: Often used in daily life / symbols.
 Kanji-Zeichen: Im Alltag häufig verwendet / Symbole.
 Caractères Kanji : souvent utilisés dans la vie de tous les jours/symboles.
 Kanji-tekens: vaak gebruikt in het dagelijks leven/symbolen.
 Caratteri Kanji: usati spesso nella vita quotidiana/nei simboli.
 Caracteres Kanji: se utilizan a menudo cotidianamente / como símbolos.
 Caracteres Kanji: usados com frequência no dia a dia / símbolos.
 Иероглифы кандзи: часто используются в повседневной жизни или как символы.



Horizontal
 Horizontal
 Horizontal
 Horizontal
 Orizontaal
 Horizontal
 Horizontal
 По горизонтали

Vertical
 Vertikal
 Vertical
 Verticaal
 Verticale
 Vertical
 По вертикали

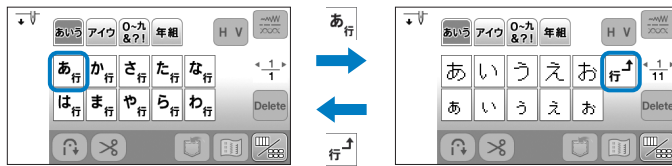

あ行



か行



さ行



た行



な行



は行



ま行



や行



ら行

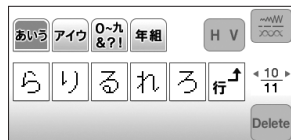

わ行



あいう アイウ 0-9 &?! 年組 H V ~nw / ~vw

ア行	カ行	サ行	タ行	ナ行	← 1 →
ハ行	マ行	ヤ行	ラ行	ワ行	Delete

↻ ⌂

ア行

あいう アイウ 0-9 &?! 年組 H V ~nw / ~vw

ア	イ	ウ	エ	オ	行 ↑	← 11 →
ア	イ	ウ	エ	オ	ヴ	Delete

↻ ⌂

ア行

あいう アイウ 0-9 &?! 年組 H V ~nw / ~vw

ア	イ	ウ	エ	オ	行 ↑	← 11 →
ア	イ	ウ	エ	オ	ヴ	Delete

カ行

あいう アイウ 0-9 &?! 年組 H V ~nw / ~vw

カ	キ	ク	ケ	コ	行 ↑	← 21 →
ガ	ギ	グ	ゲ	ゴ		Delete

サ行

あいう アイウ 0-9 &?! 年組 H V ~nw / ~vw

サ	シ	ス	セ	ソ	行 ↑	← 31 →
ザ	ジ	ズ	ゼ	ゾ		Delete

タ行

あいう アイウ 0-9 &?! 年組 H V ~nw / ~vw

タ	チ	ツ	テ	ト	行 ↑	← 41 →
ダ	ヂ	ヅ	デ	ド	ッ	Delete

ナ行

あいう アイウ 0-9 &?! 年組 H V ~nw / ~vw

ナ	ニ	ヌ	ネ	ノ	行 ↑	← 51 →
						Delete

ハ行

あいう アイウ 0-9 &?! 年組 H V ~nw / ~vw

ハ	ヒ	フ	ヘ	ホ	行 ↑	← 61 →
バ	ビ	ブ	ベ	ボ		Delete

パ行

あいう アイウ 0-9 &?! 年組 H V ~nw / ~vw

パ	ピ	プ	ペ	ポ	行 ↑	← 71 →
						Delete

マ行

あいう アイウ 0-9 &?! 年組 H V ~nw / ~vw

マ	ミ	ム	メ	モ	行 ↑	← 81 →
						Delete

ヤ行

あいう アイウ 0-9 &?! 年組 H V ~nw / ~vw

ヤ	ユ	ヨ			行 ↑	← 91 →
ヤ	ユ	ヨ				Delete

ラ行

あいう アイウ 0-9 &?! 年組 H V ~nw / ~vw

ラ	リ	ル	レ	ロ	行 ↑	← 101 →
						Delete

ワ行

あいう アイウ 0-9 &?! 年組 H V ~nw / ~vw

ワ	ヲ	ン	ー		行 ↑	← 111 →
						Delete

あいう アイウ 0-9 &?! 年組 H V ~nw / ~vw

0	1	2	3	4	5	← 13 →
6	7	8	9	○	ー	Delete

あいう アイウ 0-9 &?! 年組 H V ~nw / ~vw

二	三	四	五	六	七	← 23 →
八	九	十	&	?	!	Delete

あいう アイウ 0-9 &?! 年組 H V ~nw / ~vw

()	-	ー			← 33 →
						Delete

あいう アイウ 0-9 &?! 年組 H V ~nw / ~vw

生	年	月	日	才	保	← 12 →
育	幼	稚	園	小	中	Delete

あいう アイウ 0-9 &?! 年組 H V ~nw / ~vw

学	校	組	部	火	水	← 22 →
木	金	土	ー			Delete

- Example of Kanji characters in daily life
- Beispiel für alltägliche Kanji-Zeichen
- Exemple de caractères Kanji dans la vie quotidienne
- Voorbeeld van Kanji-tekenen in het dagelijks leven
- Esempio di caratteri kanji usati nella vita quotidiana
- Ejemplo de caracteres Kanji en la vida cotidiana
- Exemplo de caracteres Kanji no dia a dia
- Примеры использования иероглифов кандзи в повседневной жизни

一 二 三 四 五 六 七 八 九 十

1, 2, 3, 4, 5, 6, 7, 8, 9, 10

生 年 月 日

Date of birth
Data di nascita

Geburtsdatum
Fecha de nacimiento

Date de naissance
Data de nascimento

Geboortedatum
Дата рождения

一 才

1 year old
1 anno di età

1 Jahr alt
1 año de edad

1 an
1 ano

1 jaar oud
Возраст 1 год

保 育 園

Nursery school
Asilo nido

Vorschule
Guardería

Crèche
Escola maternal

Peuterspeelzaal
Ясли

幼 稚 園

Kindergarten
Scuola materna

Kindergarten
Jardín de infancia

École maternelle
Jardim de infância

Kleuterschool
Детский сад

小 学 校

Elementary school
Scuola elementare

Grundschule
Escuela primaria

École primaire
Ensino básico

Basisschool
Начальная школа

中 学 校

Junior high school
Scuola superiore

Realschule
Escuela secundaria

Collège
Ensino médio

Middelbare school
Средняя школа

組

Group/Class
Gruppo/classe

Gruppe/Klasse
Grupo/Clase

Groupe/Classe
Grupo/Classe

Groep/klas
Группа, класс

部

Club/Division
Club/sezione

Club/Abteilung
Club/División

Club/Division
Clube/Divisão

Club/Divisie
Клуб, подразделение



Moon/Monday
Luna/lunedì

Mond/Montag
Luna/Lunes

Lune/Lundi
Lua/Segunda-feira

Maan/Maandag
Луна, понедельник



Fire/Tuesday
Fuoco/martedì

Feuer/Dienstag
Fuego/Martes

Feu/Mardi
Fogo/Terça-feira

Vuur/Dinsdag
Огонь, вторник



Water/Wednesday
Acqua/mercoledì

Wasser/Mittwoch
Agua/Miércoles

Eau/Mercredi
Água/Quarta-feira

Water/Woensdag
Вода, среда



Tree/Thursday
Albero/giovedì

Baum/Donnerstag
Árbol/Jueves

Arbre/Jeudi
Árvore/Quinta-feira

Boom/Donderdag
Дерево, четверг



Gold/Friday
Oro/venerdì

Gold/Freitag
Oro/Viernes

Or/Vendredi
Ouro/Sexta-feira

Goud/Vrijdag
Золото, пятница



Soil/Saturday
Terra/sabato

Erde/Samstag
Tierra/Sábado

Terre/Samedi
Terra/Sábado

Grond/Zaterdag
Земля, суббота



Sun/Sunday
Sole/domenica

Sonne/Sonntag
Sol/Domingo

Soleil/Dimanche
Sol/Domingo

Zon/Zondag
Солнце, воскресенье

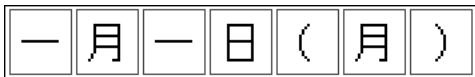

January 1st (Monday)
1° gennaio (lunedì)

1. Januar (Montag)
1 de enero (lunes)

1er janvier (lundi)
1° de janeiro (Segunda-feira)

1 januari (maandag)
1 января (понедельник)



English
German
French
Dutch
Italian
Spanish
Portuguese-BR
Russian
888-J92



D029N4-001